

---

## DRF1278F 20dBm LoRa Long Range RF Front-end Module

V1.11

---

### Features:

- Frequency Range: 433MHz
- Modulation: FSK/GFSK/MSK/LoRa
- SPI Data Interface
- Sensitivity: -139dBm
- Output Power: +20dBm
- Data Rate: <300 kbps
- 127dB dynamic Range RSSI
- Excellent blocking immunity
- Preamble detection
- Automatic RF sense and CAD monitor
- Built-in bit synchronizer for clock recovery
- Packet engine up to 256 bytes with CRC
- Working Temperature: -40°C ~+80°C
- Build-in temperature sensor
- Standby current:  $\leq 1\mu\text{A}$
- Supply voltage: 1.8~3.6V



### Applications

- Remote Control
- Smart metering
- Home Automation
- Personal data logger
- Wireless sensor network
- Remote keyless entry
- Wireless PC peripherals

### DESCRIPTION

DRF1278F is a type of low cost RF front-end transceiver module based on SX1278 from Semtech Corporation. It keeps the advantages of RFIC SX1278 but simplifies the circuit design. The high sensitivity (-139dBm) in LoRa modulation and 20dBm high power output make the module suitable for low range and low data rate applications.

DRF1278F module consists of RFIC SX1278, thin SMD crystal and antenna matching circuit. The antenna port is well matched to standard 50 Ohm impedance. Users don't need to spend time in RF circuit design and choose suitable antennas for different applications. DRF1278F operates at 1.8~3.6V with extra low standby current which makes it suitable for battery powered-up applications. Because DRF1278F is purely hardware module and it adopts  $\pm 10\text{ppm}$  crystal which the resolution of it places a important role in calculating spreading factor, bandwidth, etc. Users need to read the datasheet of SX1278 carefully in order to use the module in the best performance. DORJI also provides sample codes based on microcontroller and Arduino platform. The customers who buy the modules can contact the sales of DORJI for modifiable copies.

**PIN FUNCTIONS**

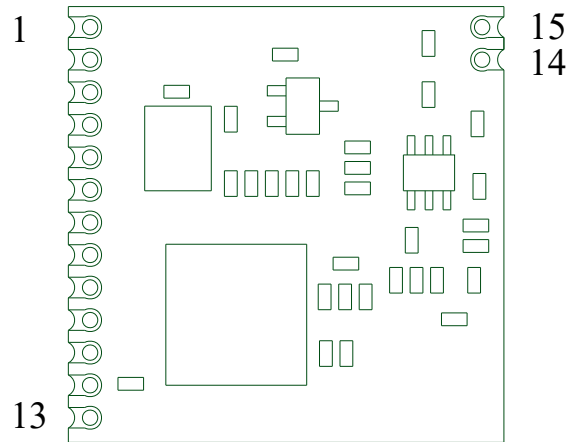

**Figure 1: DRF1278F Pin Layout**

PIN	Name	Function	Description
1	RESET	Input	Reset
2	DIO0	Input/Output	Digital I/O
3	DIO1	Input/Output	Digital I/O
4	DIO2	Input/Output	Digital I/O
5	DIO3	Input/Output	Digital I/O
6	DIO4	Input/Output	Digital I/O
7	DIO5	Input/Output	Digital I/O
8	VCC	Power	Normal 3.3V
9	GND	Ground	Ground (0V)
10	SCK	Input	SPI clock input
11	MISO	Output	SPI data output
12	MOSI	Input	SPI data input
13	NSS	Output	SPI chip select input
14	GND	Ground	Ground (0V)
15	ANT	Ground	50 Ohm Impedance

**Table 1: DRF1278F Pin Functions**

## ELECTRICAL SPECIFICATIONS

Symbol	Parameter (condition)	Min.	Typ.	Max.	Units
VCC	Supply Voltage	1.8		3.6	V
Temp	Operating temperature range	-40	25	80	°C
Freq	Frequency range	410	433	460	MHz
IDD_R	Current in receive mode		12		mA
IDD_T	Current in transmit mode		120	125	mA
IDD_S	Current in sleep mode.			1	uA
Pout	Max. output power		20		dBm
Sen	Receiver sensitivity @LoRa 300bps			-136	dBm
ZANT	Antenna Impedance		50		Ohm

Table 2: DRF1278F Electrical Specifications

## ABSOLUTE MAXIMUM RATINGS

Symbol	Parameter	Min.	Max.	Units
VCC	Supply Voltage	-0.3	3.6	V
VI	Input voltage	-0.3	VCC+0.3	V
VO	Output voltage	-0.3	VCC+0.3	V
T <sub>ST</sub>	Storage temperature	-55	125	°C

Table 3: DRF1278F Maximum Ratings

APPLICATION CIRCUIT

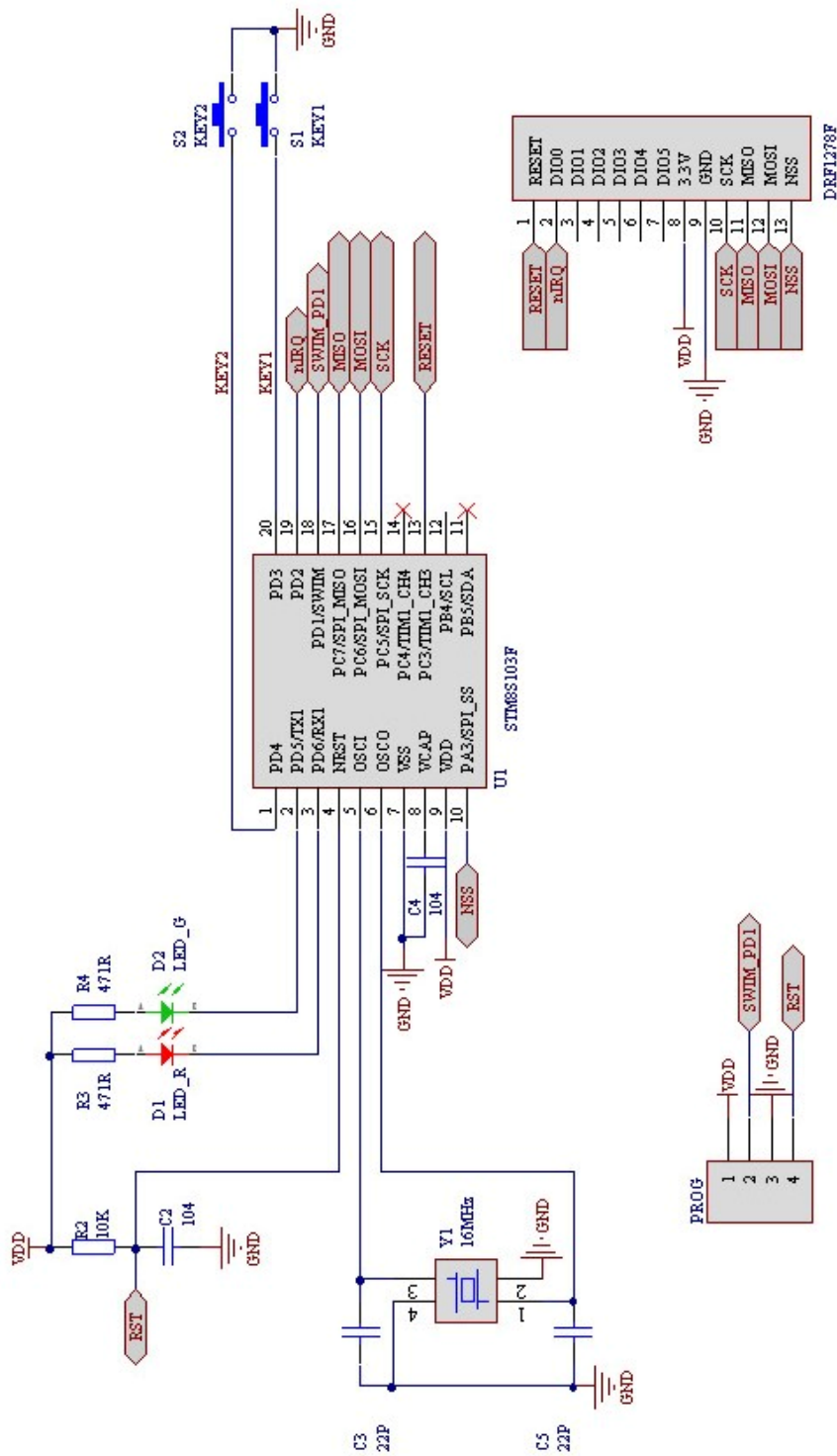
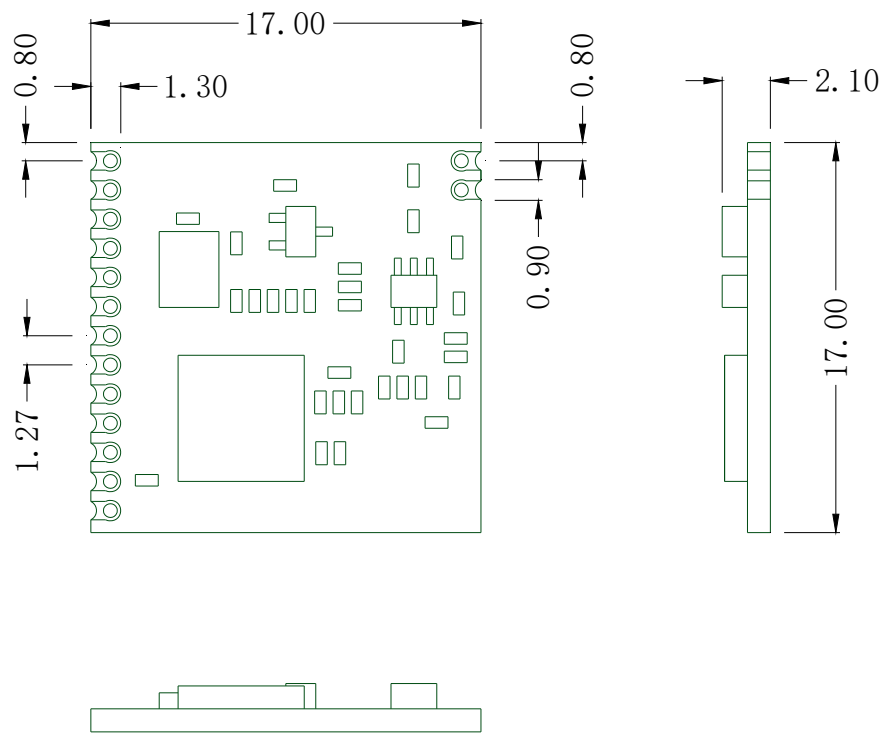

Figure 2: Application Circuit

**MECHANICAL DATA**

Unit: mm



**Figure 3: Mechanical Dimension**

**REFERENCE DOCUMENTS**

1. [SX1278 Datasheet](#)
2. [LoRa Calculator](#)
3. [LoRa Low Energy Design Guide](#)
4. [LoRa Modem Designer's Guide](#)
5. [SX1276 Development Kit User Guide](#)

<p>orji Applied Technologies A division of <i>Dorji Industrial Group Co., Ltd</i></p> <p>Add.: Xinchenuayuan 2, Dalangnanlu, Longhua, Baoan district, Shenzhen, China 518109</p> <p>Tel: 0086-755-28156122 Fax.: 0086-755-28156133 Email: <a href="mailto:sales@dorji.com">sales@dorji.com</a> Web: <a href="http://www.dorji.com">http://www.dorji.com</a></p>	<p>Dorji Industrial Group Co., Ltd reserves the right to make corrections, modifications, improvements and other changes to its products and services at any time and to discontinue any product or service without notice. Customers are expected to visit websites for getting newest product information before placing orders.</p> <p>These products are not designed for use in life support appliances, devices or other products where malfunction of these products might result in personal injury. Customers using these products in such applications do so at their own risk and agree to fully indemnify Dorji Industrial Group for any damages resulting from improper use.</p>
---	---